

Measurement Standard for Monitoring Performance of Machine Tools in Harsh Environmental Condition

Bojan Acko^{1,*}, Matjaz Milfelner²

*1 University of Maribor, Faculty of mechanical Engineering, Maribor, Smetanova 17, Slovenia
2 EMO Orodjarna d. o. o., Bežigrajska cesta 9, SI-3000 Celje, Slovenia*

** Corresponding author: bojan.acko@um.si*

Abstract

In order to introduce traceability chain into in-process geometrical measurements, European project EMRP IND62 TIM was agreed between EC and Euramet. Within the project, highly accurate robust measurement standards for using in harsh environmental conditions will be developed. The task of the Laboratory for Production measurement at the University of Maribor is to develop, manufacture and calibrate a 1D measurement standard with length up to 2 m and with thermal expansion coefficient close to 0. The task is being performed in co-operation with EMO Orodjarna and Vepas. The article is presenting basic design characteristics and application possibilities of this standard.

1 Introduction

The principle of in-process metrology is to obtain measurement data directly in the manufacturing process and to use them for effective process control and for reliable quality assurance. One prerequisite to significantly improve the manufacturing processes is the incorporation of traceable dimensional metrology directly on machine tools.

Measurement traceability is founded on the national standards, which are provided to the industrial end-users by national metrology institutes (NMIs). Achieving traceable and reliable dimensional measurements on the shop floor requires the standards that are deployable on machine tools to be robust and non-susceptible to the environmental conditions on the manufacturing floor. Control of thermo-mechanical errors on the machine tool is not the responsibility of the machine tool manufacturers alone. Machine tool end-users require qualified and calibrated standards and procedures to guide them to mitigate, control and correct the errors. Neither the machine tool manufacturers nor the end-users have the required stable standards to do the corrections in real-life machining conditions. Furthermore, existing standards for machine calibration do not adequately address the environmental conditions on the shop floor. Therefore there is an urgent need for a new generation of robust material standards with corresponding procedures and guidelines for the assessment of machine tool measurement performance directly on the shop floor [1].

2 Temperature-invariant ball bar standard

The standard will be used for checking geometrical properties of machining centres with various production volumes (up to 3 m per axis) and various numbers of axes [2, 3]. The metrological check will be performed with no load. As a result, metrological check will return machine tool compliance with specification (MPEs). No error mapping like in some other traceability approaches is expected to be performed by using the metrological results. The machining centre under test shall be equipped with a tactile probing system attached on the machine (normally in the tool holder).

The performance test will be executed in the main axes (x, y, z) and optionally also in spatial diagonals [3]. Up to 4 different lengths (500 mm, 1000 mm, 1500 mm and 2000 mm) in different axial or spatial positions will be measured. The deviations will be calculated as measured values (measured by the machine tool) minus calibrated distances between ball centres.

2.1 Dimensional attributes

The standard is designed as a modular ball-bar artefact that can materialise 4 lengths:

- 500 mm
- 1000 mm
- 1500 mm
- 2000 mm

Materialised measure is the distance between ball centres. The concept is shown in Figure 1.

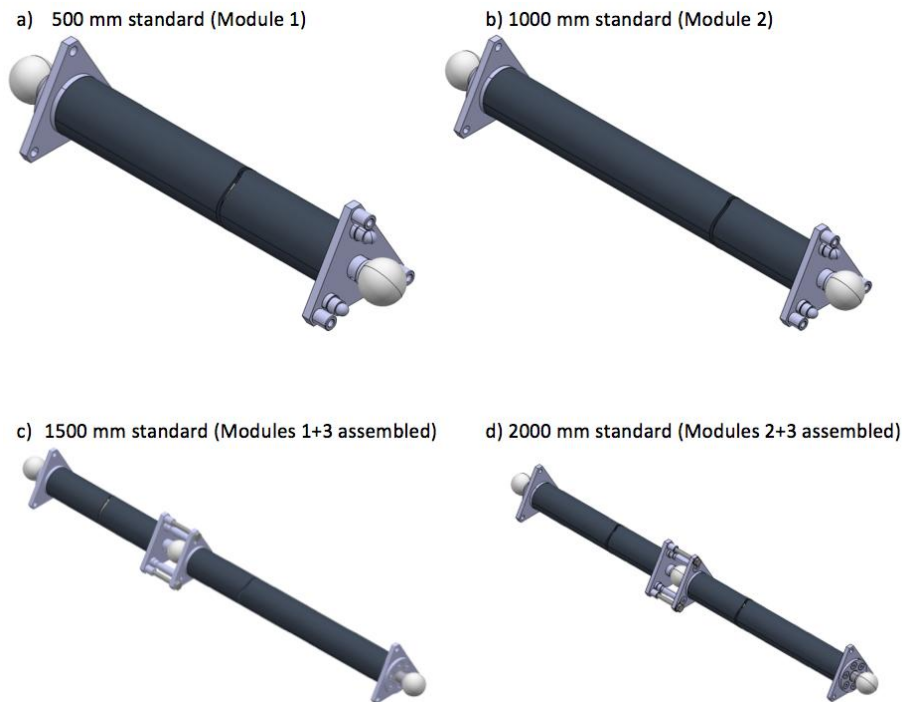

Figure 1: Conceptual design of the standard.

2.2 Probing surfaces

Probing elements (balls) are made of ceramics. Since it is intended to be used for calibrating contact (tactile) measurement systems, surface appearance (shining/non-shining) is not of big importance. The most important feature is spherical shape. The ceramic balls will be purchased at known producer (experiences from past available). The maximum allowable deviation of sphericity is 0,5 μm . Surface features of other constructional parts have no influence on metrological properties of the standard.

2.3 Materials of construction elements

Different materials are used for different constructional parts of the standard. The materials of main constructional parts are listed below:

- Main body (tube) – composite material (carbon fibers in epoxy matrix),
- Bases (joints) – steel,
- Ball holders – steel,
- Compensator for thermal expansion – aluminum,
- Probing balls – ceramics.

Materials were chosen on the bases of experiences with similar standards. Temperature expansions, resistance against liquids (water, oils, ...), bending and surface properties (probing elements) were considered while choosing materials. Composite material was chosen for the main body of the

standard because of its rigidity, low temperature expansion and low weight (the standard should be easily transportable). Alternative material for the main body of the standard would be e.g. invar, which has similar properties as regards metrology (expansion, bending), but would be heavier and much more expensive. The ceramic material for probing balls has almost no equivalent alternative as regards surface properties (sphericity, hardness, resistance against liquids) and is therefore used worldwide in similar cases. Stainless steel was chosen for all coupling elements due to its resistance to corrosion and machining properties. Economic aspects were considered as well. Aluminum is used for the “temperature compensator” due to its appropriate and temperature expansion coefficient, which can be precisely determined.

2.4 Stability

Metrological stability of the standard in terms of ball distance changes is expected to be less than 1 $\mu\text{m}/\text{year}$. More critical feature could be length change due to bending and compression under different conditions of use (single module, combined modules, position in space – horizontal, vertical, spatial angle). Preliminary research was performed by using finite element method. The results have shown that the maximum expected error in terms of ball distance change was within 1 μm .

2.5 Design

The standard consists of three modules. Two modules (1 and 2) are ball standards of different lengths (Module 1 – 500 mm, Module 2 – 1000 mm) that can be used separately or in combination with Module 3 (which is only an extension and can not be used separately). Each module contains a “temperature compensator”, which compensates thermal expansion of the composite tube (main body of the standard).

Detailed design of modules 1 and 2 is shown in Figure 2.



Figure 2: Design of modules 1 and 2.

2.6 Compensator of thermal expansion

In order to achieve length stability in harsh environmental conditions, the standard is equipped with an active thermal expansion compensator (Fig. 3).

The compensator is made of two different materials with significantly different thermal expansion coefficients. The tube (Pos. 12, 13, 14 in Fig. 3) is made of aluminium, while the flange (Pos. 8), the ball holder (Pos. 9, 10, 11), the tube cover (Pos. 15), and the nut (Pos. 26) are made of steel. The flange (Pos. 8) is attached to the composite tube – main body of the standard.

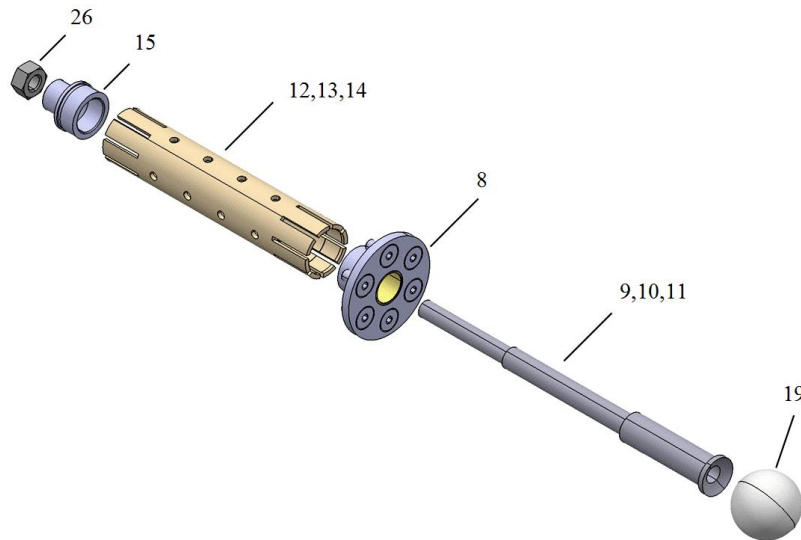

Fig. 3: Thermal expansion compensator.

If the ambient temperature is increased, the composite tube is expanding in “positive” direction, while the aluminium tube is expanding in the opposite direction and pulls the ceramic ball (Pos. 19) inside the main body of the artefact.

3 Traceability

3.1 Metrological characterisation

Metrological characteristics of the standard will be available in the form of a calibration certificate, stating 4 distances between line centers (at nominal values 500 mm, 1000 mm, 1500 mm, and 2000 mm). The data will be available in paper as well as in electronic (txt file) form.

3.2 Calibration process

The standard will be calibrated by using tactile three coordinate measuring machine ZEISS UMC 850. Three modules will be calibrated separately by applying normal measurement procedure (probing balls in at least 20 points each, repeating measurements 5 times for each distance, calculating average distances and standard deviations). The ball distances on combined modules (see Fig. 1 c and d) will be calculated by considering geometrical properties of joints between the modules.

3.3 Uncertainty of measurement

The standard will be with expected expanded uncertainty $U = 2,1 \mu\text{m} + 3,3 \cdot 10^{-6} \cdot L$ ($k = 2$; level of confidence 95 %). The uncertainty [4] is defined by the verification test of the coordinate measuring machine used for calibration.

4 Conclusion

The project aimed for assuring traceability of in-process measurements EMRP TIM [1] is currently in the design phase. Different standards were designed, and manufacturing techniques were defined as well. In the following project phases, the standards will be produced and calibrated. The presented standard will be produced by three Slovenian unfunded industrial partners in the project: Gorenje Orodjarna, EMO Orodjarna and Veplas. It will be calibrated in the Laboratory for Production Measurement at the University of Maribor.

Very important part of the project is also development and validation of procedures for calibrating and verifying machine tools under harsh environmental conditions. The procedures will be validated by test measurements in real shop-floor conditions. Unfunded industrial partners from different countries will be involved in this validation phase. One of the final goals of this validation phase is to determine uncertainty of measurement in calibration and verification [4]. It is expected that the contribution of short term and long term geometrical stability of the standards will have no significant influence on the total measurement uncertainty.

Acknowledgement

The authors would like to acknowledge funding of the presented research within the European Metrology Research Programme (EMRP) in the Joint Research Project IND62 TIM. Furthermore, fruitful professional discussions within the research group, especially with National Physical Laboratory (NPL) and Physikalisch Technische Bundesanstalt (PTB), are highly appreciated.

References

- [1] Wendt K 2013 IND62 TIM – Traceable in-process dimensional measurement, *EMRP JRP protocol* PTB Braunschweig
- [2] Schwenke H, Knapp W, Haitjema H, Weckenmann A, Schmitt R and Delbressine F 2008 Geometric error measurement and compensation of machines—An update, *CIRP Annals - Manufacturing Technology* **57** 660-675
- [3] ISO 230-1 2012 Test code for machine tools - Part 1: Geometric accuracy of machines operating under no load or finishing conditions *ISO copyright offic, Geneva*
- [4] ISO/TR 230-9 2012 Test code for machine tools - Part 9: Estimation of measurement uncertainty for machine tool tests according to series ISO 230, basic equations *ISO copyright office Geneva*