

# **Good Practice Guide on Making Rectangular Waveguide Connections at Frequencies above 100 GHz**

**Thorsten Probst, Karsten Kuhlmann, Nick Ridler, James Watts**

July, 2019

This document and all parts contained therein are protected by copyright and are subject to the Creative Commons user license CC BY-ND 4.0 (<https://creativecommons.org/licenses/by-nd/4.0/deed.en>).



**Suggestion for the quotation of the references:**

Probst, Thorsten ; Kuhlmann, Karsten ; Ridler, Nick ; Watts, James.  
Good Practice Guide on Making Rectangular Waveguide Connections at  
Frequencies above 100 GHz, 2019. Physikalisch-Technische Bundesanstalt.  
DOI: <https://doi.org/10.7795/530.20190805>

### Acknowledgement

The authors acknowledge support by the European Metrology Programme for Innovation and Research (EMPIR) Project 17SIP08 “New Waveguide Interfaces for Terahertz Technologies”. The EMPIR program is co-financed by the participating countries and from the European Union’s Horizon 2020 research and innovation program.

## Contents

<b>1</b>	<b>Introduction</b>	<b>1</b>
1.1	Overview of rectangular waveguide standard documents . . .	1
1.2	Waveguide designation and compatibility . . . . .	3
1.3	Rectangular waveguide basics . . . . .	3
<b>2</b>	<b>The IEEE 1785 series of standards</b>	<b>5</b>
2.1	IEEE Std 1785.1-2012 . . . . .	6
2.2	IEEE Std 1785.2-2016 . . . . .	6
2.3	IEEE Std 1785.3-2016 . . . . .	7
<b>3</b>	<b>Performing precise measurements</b>	<b>9</b>
3.1	Preparations . . . . .	9
3.2	Measurement set-up . . . . .	11
3.3	Some practical tips . . . . .	13
3.3.1	Use of a precision waveguide section as a test interface	14
3.3.2	Different waveguide apertures . . . . .	14
3.3.3	Waveguide to coaxial adapters . . . . .	14
3.4	Example Measurements . . . . .	15
3.4.1	Measurements for 75 to 110 GHz: WR10 / WM-2540 / R 900 / WG 27 . . . . .	16
3.4.2	Measurements for 220 to 330 GHz: WR3 / WM-864 / R 2.6k / WG 32 . . . . .	21
<b>4</b>	<b>Software</b>	<b>23</b>
4.1	Software for Uncertainty Calculation of Waveguide Connections	23
	<b>References</b>	<b>24</b>

## **Purpose**

At frequencies of approximately 100 GHz and above, rectangular metallic waveguide is often the preferred transmission medium for making reliable, precision, measurements. A prerequisite for these types of measurements is the use of the correct types of waveguide interface, and, the need to follow the correct operating procedures. This document is aimed at people interested in making reproducible measurements with relatively low measurement uncertainty, in rectangular waveguide, at these frequencies. It can be considered as a supporting document for existing standards that are available for waveguide and waveguide interfaces used at these frequencies (e.g. as published by IEEE, IEC, MIL, EIA, etc). This document concentrates on rectangular waveguides. However, many aspects that are presented might also be applicable to circular waveguides.

## 1 Introduction

### 1.1 Overview of rectangular waveguide standard documents

Today the IEC and IEEE are the two main international standardisation bodies for rectangular waveguides for use at frequencies above 100 GHz. Other standardisation bodies, such as United States Military (MIL), the Electronic Industries Alliance (EIA) or the United Kingdom Ministry of Defence (MoD), are also referenced by some manufacturers, although some of these documents are no longer maintained. Table 1 lists the latest editions of these documents.

Standard	Dimension	Interface	Publication year	$f_{max}$ / GHz
MIL-DTL-85/3D	X	X	2012	325
Std1785.1-2012 [1]	X	X	2012	3300
IEC 60153-2:2016 [2]	X	X	2016	3300
EIA RS-261-B:1979	X	X	1979	325
MIL-DTL-3922/67E w/Amendment 1[3]		X	2014	110
IEEE Std1785.2-2016 [4]		X	2016	3300
IEC 60154-2:2016 [5]		X	2016	3300

**Table 1.** Selection of existing standards for rectangular waveguides.

Usually, one standard provides information concerning the frequency bands and the associated waveguide aperture sizes, and another standard describes the waveguide interfaces (also referred to as flanges). In the 5<sup>th</sup> column of Table 1,  $f_{max}$  indicates the highest frequency the standard supports. In 2012 and 2016 IEEE and IEC published new standards to cover frequency bands up to the terahertz frequency region [1], [2], [4], [5].

Figure 1 shows an example of a waveguide flange used at millimetre(mm)-wave frequencies and above. Usually, the waveguide opening (aperture) is centred, while the alignment and connection mechanisms (i.e. dowels, holes, and threaded holes) are placed around the aperture.

A more complete overview about existing waveguide sizes and flanges can be found in [6]–[9].

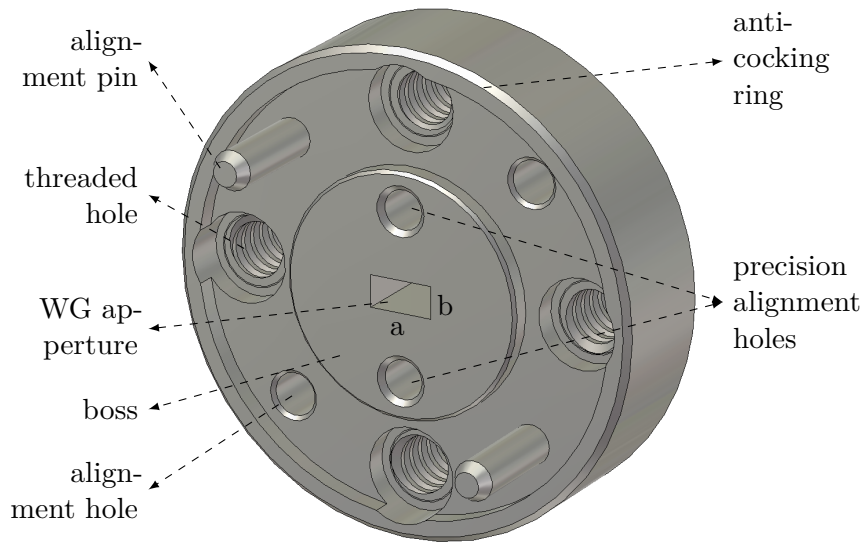


Fig. 1. Example flange for rectangular waveguide.

Waveguide Designation				$f$ / GHz
IEEE WM-	MoD WG	IEC R	EIA WR	
2540	27	900	10	75-110
2032	28	1.2k	8	90-140
1651	29	1.4k	7	110-170
1295	30	1.8k	5	140-220
1092	31	2.2k	4	170-260
864	32	2.6k	3	220-330
710	-	3.2k	-	260-400
570	-	4k	-	330-500
470	-	5k	-	400-600
380	-	6.2k	-	500-750
310	-	7.4k	-	600-900
250	-	9k	-	750-1100
200	-	12k	-	900-1400
164	-	14k	-	1100-1700
130	-	18k	-	1400-2200
106	-	22k	-	1700-2600
86	-	26k	-	2200-3300

Table 2. Overview of rectangular waveguide designations for selected frequencies[6].

## 1.2 Waveguide designation and compatibility

Table 2 gives an overview of some common waveguide designations. The recommended frequency ranges specified in the different standards might vary slightly, thus rounded values are used here.

Most standardised flanges from IEEE and IEC are mechanically compatible with older designs (e.g. from MIL, EIA, MoD, etc.) of the same type of flange and compatible with each other, though the electrical performance might be significantly degraded [10]. One exception is IEEE 1785.2c, which is a plug and jack design. Only the plug type design is compatible with the other flanges.

In practice, many manufacturers of waveguide components for use at frequencies above 100 GHz have chosen to mitigate this performance degradation by deviating from the standard designs. This is typically achieved by increasing the diameter of the alignment pins or reducing the diameter of the alignment holes. Whilst these non-standard flanges can still be mated with each other and with standardised flange designs, some combinations of manufacturers' flanges will not mate at all due to the impact of tolerances on the critical dimensions. If it is not known which standards a pair of flanges follows, one must make the connection very carefully.

Most waveguide interfaces follow a similar connection strategy. There is basically one flange design for several frequency bands, and the alignment is realised via holes and dowels with a certain precision. However, there are some exceptions, e.g. flange type G (IEC 60154-2:2016 [5]). In IEEE 1785.2-2016, there are actually three different flanges designs, and the alignment mechanisms are somewhat different when compared to each other, or to flange designs given in other standards. This will be described in detail in Section 2.2.

A more complete overview of flange compatibility can also be found in [6], [9].

## 1.3 Rectangular waveguide basics

In this section, some equations are given relating to the propagation characteristics of these waveguides. This kind of information is usually provided by waveguide manufacturers.

The cut-off frequency  $f_c$  for the rectangular waveguide [1] is

$$f_c = \frac{c}{\sqrt{\epsilon_r}} \cdot \frac{1}{2 \cdot a} \quad (1)$$

where

$c$  : is speed of electromagnetic waves in vacuum, defined as 299 792 458 m/s

$\epsilon_r$  : is relative permittivity

$a$  : is waveguide broad wall dimension

The attenuation constant  $\alpha$  can be approximated [1] with

$$\alpha = 0.023273 \cdot \sqrt{\frac{\rho}{\rho_0}} \cdot \frac{1}{b\sqrt{a}} \cdot \frac{\left(\frac{f}{f_c}\right)^2 + \frac{2b}{a}}{\sqrt{\frac{f}{f_c}} \cdot \sqrt{\left(\frac{f}{f_c}\right)^2 - 1}} \text{ dB/cm} \quad (2)$$

where

$\rho$  : is resistivity of the waveguide conductor

$\rho_0$  : is reference resistivity = 17.241 n $\Omega$ ·m

$a$  : is waveguide broad wall dimension in mm

$b$  : is waveguide narrow wall dimension in mm

$f_c$  : is cut-off frequency in GHz

$f$  : is frequency at which attenuation constant is calculated in GHz

Equation (2) does not hold for thinly plated surfaces (e.g. where the plating thickness is less than two times the skindepth) and also neglects any effects due the surface roughness of the waveguide or other defect (e.g. cracks or gaps in the internal corners of the waveguide). The skindepth [11] is

$$\delta = \sqrt{\frac{\rho}{\pi f \mu}} = \sqrt{\frac{2\rho}{\omega \mu}} = \frac{1\rho}{R_S} \quad (3)$$

where

$\mu$  : is permittivity

$R_S$  : is surface resistance

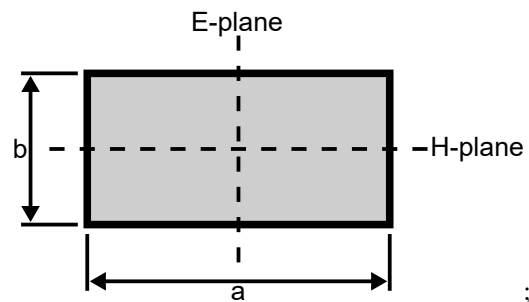
Great care should be taken in using this equation for waveguides where the waveguide cross section is not formed from a single conductor (e.g. waveguides formed from a machined channel and a flat cover). Imperfect conduction at the joins of these parts can give rise to significantly greater attenuation.

The information given in this section is only accurate for single mode operation and for the first **T**ransverse **E**lectric mode TE<sub>10</sub>. This means, that the electric field is transverse to the direction of propagation, while the magnetic field has components in the direction of propagation. Field illustrations can be found e.g. in [11].

The field orientation of the TE<sub>10</sub> mode is also the reason for the naming of the two reference planes E-plane and H-plane in rectangular waveguides (see Figure 2).

The terms E-plane and H-plane are also used in antenna measurements and for other microwave devices to indicate the orientation of the polarisation of of the electromagnetic radio waves.





**Fig. 2.** Reference planes in rectangular waveguides.

## 2 The IEEE 1785 series of standards

At around the beginning of this century, there was a significant increase in use of the millimetre-wave part of the spectrum for commercial applications in electronics, materials science and communications. In response to this increase in usage, commercial test equipment gradually became available. Companies such as OML [12] or RPG [13] started developing accessories for vector network analysers that enabled the operating frequency to be extended above 110 GHz [14]. These measurement capabilities were extended subsequently to at least 500 GHz [15]. Other companies, such as VDI [16], continued this trend, developing systems that operated to beyond 1 THz [17]. During the first decade of this century, there was a realisation that knowledge and standardisation of waveguide at these frequencies was rather limited [18]. Schemes were subsequently proposed to extend waveguide sizes to cover these millimetre and submillimetre-wave frequencies [19]–[21]. However, none of these proposed waveguide sizes had been standardised or completely accepted by the end-user community. This led to the initiation of an IEEE standardisation activity, started in 2008, to provide standardised waveguide sizes for use at these frequencies. At the same time, it was widely recognised that the electrical and mechanical performance of existing waveguide flanges was inadequate for use at these frequencies. The IEEE standardisation activity aimed to address this issue as well.

The IEEE Standards Association set up and launched the Working Group P1785. Beginning in 2008, three standards covering (i) the waveguide sizes, (ii) waveguide interface, and (iii) typical uncertainty specifications for measurements at these frequencies were developed. This resulted in the publication of the following three standards:

- (i) 1785.1-2012: “IEEE Standard for Rectangular Metallic Waveguides and Their Interfaces for Frequencies of 110 GHz and Above—Part 1: Frequency Bands and Waveguide Dimensions”
- (ii) 1785.2-2016: “IEEE Standard for Rectangular Metallic Waveguides and Their Interfaces for Frequencies of 110 GHz and Above—Part 2:

Waveguide Interfaces”

- (iii) 1785.3-2016: “IEEE Recommended Practice for Rectangular Metallic Waveguides and Their Interfaces for Frequencies of 110 GHz and Above—Part 3: Recommendations for Performance and Uncertainty Specifications”

Brief descriptions of each of these standards are given in the following.

## **2.1 IEEE Std 1785.1-2012**

This standard gives specifications for waveguide used 110 GHz and above, including aperture dimensions, frequency range, and cut-off frequency [1]. The standard considers the tolerances of the waveguide aperture dimensions and the effect these have on the return loss of the waveguide.

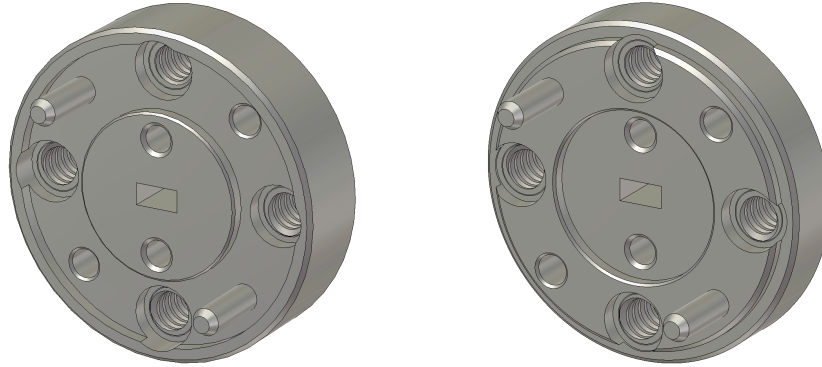
The standard lists a series of waveguide sizes for use at frequencies up to 3.3 THz. The standard also introduced a new naming convention for waveguide sizes at these frequencies. Since the sizes are defined in terms of metric units, the letters WM are used to indicate that the size refers to **W**aveguide using **M**etric dimensions. The numbers that follow these letters correspond to the broad wall dimension of the waveguide specified in micrometre ( $\mu\text{m}$ ). For example, WM-250 refers to waveguide with a broad wall dimension of 250  $\mu\text{m}$ . The standard gives a procedure for extending the waveguide sizes to frequencies above 3.3 THz. The standard also defines different grades of waveguide based on the tolerance of the aperture dimensions. For example, if the dimensional tolerances are less than 0.2% of the broad wall dimension, then this waveguide is graded as 0.2. The reflection coefficient resulting from these tolerances are also listed in the standard. The standard also gives calculated values of attenuation constant (in dB/cm) due to loss in the waveguide conductor walls.

## **2.2 IEEE Std 1785.2-2016**

This standard gives specifications for the waveguide flanges, see Figure 3 [4]. It considers the tolerances of flange dimensions and the effect these have on the electrical performance of the waveguide. The standard describes three different types of waveguide flanges. These are:

- Precision Dowel flange (IEEE 1785-2a), which uses two insertable dowels (of different diameters) as the main alignment mechanism (see Figure 3(a))
- Ring-Centered flange (IEEE 1785-2b), which uses a centring ring as the main alignment mechanism (see Figure 3(a))

- Plug and Jack flange (IEEE 1785-2c), which uses a plug and jack (socket) arrangement as the main alignment mechanism (see Figure 3(b))



(a) Drawing of IEEE Std 1785.2-2016 ver-  
sions 2a and 2b Plug (b) Drawing of IEEE Std 1785.2-2016 ver-  
sion 2c Jack

**Fig. 3.** IEEE flanges (a) 1785.2a and 1785.2b and (b) 1785.2c.

All three flanges are mechanically compatible with each other, and with the UG-387 flange [3] and related flanges, though an adapter may be required for IEEE1785.2c (Jack). However, the electrical performance when mated to the UG-387 type of flange is not as good as when mating the above three flange types with themselves.

The standard shows engineering drawings and the alignment structures (i.e. the dowels and centring ring) for the three flanges, and it gives information concerning the return loss due to the dimensional tolerances. The two insertable dowels of different diameters for flange IEEE1785.2a are marked with a triangle for the angular alignment dowel and a rectangle for the planar alignment dowel. In Table 3, an overview of the use of these dowels is given. Either of both IEEE1785.2a dowels can be combined with a dowel from the IEC standard. The OK in Table 3 indicates, that this dowel combination will work from a mechanical point of view, but it is not the best choice electrically. Best performance, which here means lowest return loss and highest repeatability, will be achieved if both types of IEEE1785.2a dowels (angular and planar) are used. A combination of two planar alignment dowels is very likely to cause the interface to bind and so should be avoided.

### 2.3 IEEE Std 1785.3-2016

This standard is somewhat different from a classical standard [22]. Instead it is a Recommended Practice document. As such, it gives recommendations rather than mandatory requirements for determining the electrical performance and expected measurement uncertainty, in terms of return loss, of

	IEC alignment dowel	IEEE	
		<b>angular</b> (◄) alignment dowel	<b>planar</b> (■) alignment dowel
IEC alignment dowel	OK	OK	OK
IEEE <b>angular</b> (◄) alignment dowel	OK	OK	best performance
IEEE <b>planar</b> (■) alignment dowel	OK	Best performance	Causes interface to bind

**Table 3.** Overview on dowel combinations for flange IEEE1785.2a.

waveguide apertures and flanges. The information also enables a complete measurement uncertainty analysis to be performed.

The recommendations give methods for examining and communicating uncertainties that are associated with more detailed dimensional imperfections in the waveguide apertures and flanges than those given in IEEE Std 1785.1-2012 and IEEE Std 1785.2-2016. These recommendations provide the end user with an easy-to-understand summary of the dominant errors and all information required to perform a complete uncertainty analysis using a common format.

The document lists the dimensional data needed to undertake the uncertainty analysis. This includes the height, width and corner radius of the waveguide aperture; and, the lateral displacement of the aperture due to linear and angular flange misalignment. Guidance is also given on the propagation of uncertainty from the dimensional data to electrical performance data (in terms of return loss). Finally, guidance is given on summarising and reporting the information. This includes plots showing the electrical performance, an example uncertainty budget, and details of software that adheres to the recommendations given in the standard.

### **3 Performing precise measurements**

This chapter gives some practical tips on how to prepare and perform precise waveguide measurements.

Extensive and meticulous preparation of the measurement schedule enables efficient operation of the measurements and also enables complete and detailed documentation (for Quality Management purposes). Firstly, in section Section 3.1, the importance of a thorough preparation is described. Section 3.2 introduces typical VNA and frequency extender head set-ups. Section 3.3 presents good measurement practice information. However, when working with VNAs and performing precise measurements, a study of the Guidelines on the Evaluation of Vector Network Analysers (VNA)[23] is recommended. This chapter also includes some example measurements in Section 3.4 pointing out typical effects and selected examples of measurements at 100 GHz and above.

#### **3.1 Preparations**

At the beginning of each calibration and measurement series there should be a sound and extensive preparation to ensure a subsequent smooth measurement process. Here, without claim of completeness, five lists are given to help with the preparations for typical 1- and 2-port waveguide measurements. Additionally, for VNA measurements above 100 GHz, frequency extenders are usually required. Therefore, extenders will always be present in the following descriptions.

- 1. Environmental conditions**

- (a) Try to ensure stable laboratory temperature and humidity.
- (b) Arrange for a clean and uncluttered workspace.

- 2. Detailed measurement and calibration schedule**

- (a) Optimise the workflow for all necessary measurements.
- (b) Keep any cable movements to a minimum.
- (c) Develop a schedule for the measurements (this is also useful for documentation purposes).

- 3. Optimised system set-up, test and handling.**

- (a) Check the parameters for the frequency extenders in the VNA set-up. This is usually given by the manufacturer.
- (b) Check the power-level of the input signals for the frequency extenders with a calibrated power meter, if available.
- (c) For 2-port measurements: carefully align the VNA frequency extenders.

- (d) Check set-up functionality with simple tests (e.g. blocking the transmission path with a suitable obstacle to ensure a drop in observed signal transmission).
- (e) Perform some simple repeatability and drift tests.

#### **4. Supporting tools and devices**

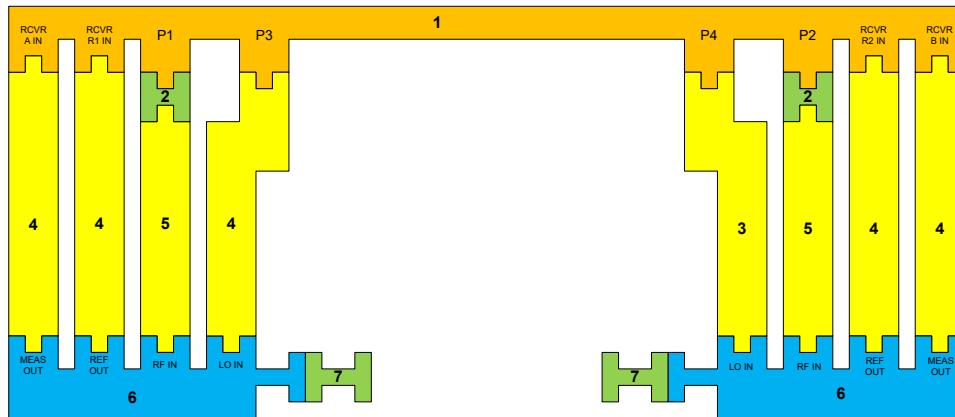
- (a) Support the cables. Avoid freely suspended cables and bending in more than one dimension.
- (b) If possible, fix the position of one frequency extender.
- (c) Use precision calibration kits and ensure that their mating faces are clean, flat and undamaged.
- (d) Check for correct size and length of screws and dowels.
- (e) If possible, use torque drivers for all connections [24].
- (f) Prepare cleaning equipment (compressed air, cleaning rag and solvent) [25].

#### **5. Documentation**

- (a) Document all serial and model numbers of the equipment that is used for the measurements. For example:
  - i. VNA
  - ii. Frequency extenders
  - iii. Calibration kit
  - iv. Cables
  - v. DUTs
- (b) Take photographs and create schematic drawings of the set-up

### 3.2 Measurement set-up

It is in accordance with good scientific practice to make pictures and schematic drawings of the measurement set-ups. In Figure 4 a typical set-up for measurements with frequency extenders and a 4-port VNA is shown. All essential



**Fig. 4.** Schematic measurement set-up with 4-port VNA and frequency extenders.

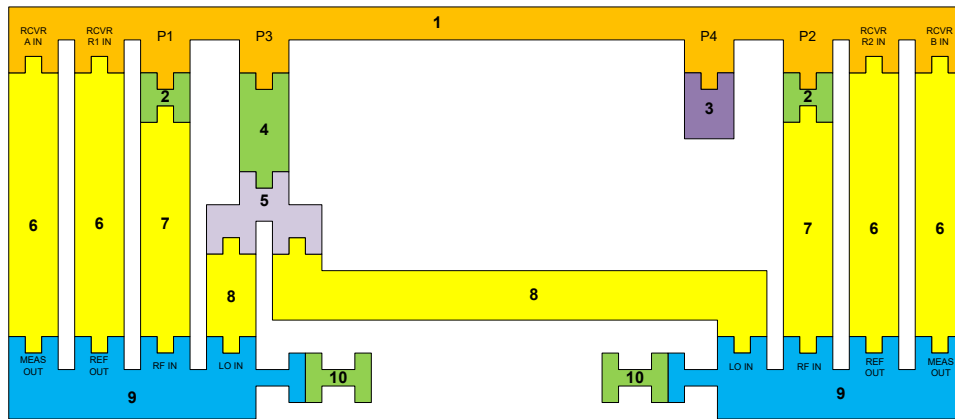
- 1 : 4-port VNA
- 2 : Adapter 2.4 mm jack →3.5 mm jack
- 3 : Cable 3.5 mm jack→3.5 mm plug
- 4 : Cable 2.4 mm plug→2.92 mm plug
- 5 : Cable 2.92 mm plug→2.92 mm plug
- 6 : Frequency Extender
- 7 : Adapter WM-2540 →WM-2540

parts are numbered and a short description is added. For completeness, the serial and model numbers should be added.

Alternatively, the set-up in Figure 4 can be modified as shown in Figure 5. Here, the LO signal is distributed from one port (P3) to both extenders with a power splitter. This is often advantageous, because, due to different internal amplifiers and attenuators, the LO signal might show different drift behaviour when coming from two VNA ports [26].

If only a 2-port VNA is available, the LO signals can be provided with an additional signal generator, as shown in Figure 6. The controlling of the signal generator is usually done by the VNA firmware, and the reference clocks of both devices must be locked. This is usually achieved using a 10 MHz signal. As the actual internal clock is often not 10 MHz (e.g. several hundreds of MHz), the signal is internally down converted. This, and the fact that now two measurement instruments are part of the set-up, might lead to more system drift and/or noise. Usually, the set-up depicted in Figure 5 shows the best behaviour.

If pictures are taken of the measurement set-up, they should clearly show,



**Fig. 5.** Alternative schematic measurement set-up with 4-port VNA and frequency extenders.

- 1 : 4-port VNA
- 2 : Adapter 2.4 mm jack →3.5 mm jack
- 3 : 1.85 mm termination
- 4 : Adapter NMD2.4 mm plug →NMD3.5 mm jack
- 5 : Power Splitter 3.5 mm jack
- 6 : Cable 2.4 mm plug →2.92 mm plug
- 7 : Cable 2.92 mm plug →2.92 mm plug
- 8 : Cable 3.5 mm plug →3.5 mm plug
- 9 : Frequency Extender
- 10 : Adapter WM-2540 →WM-2540

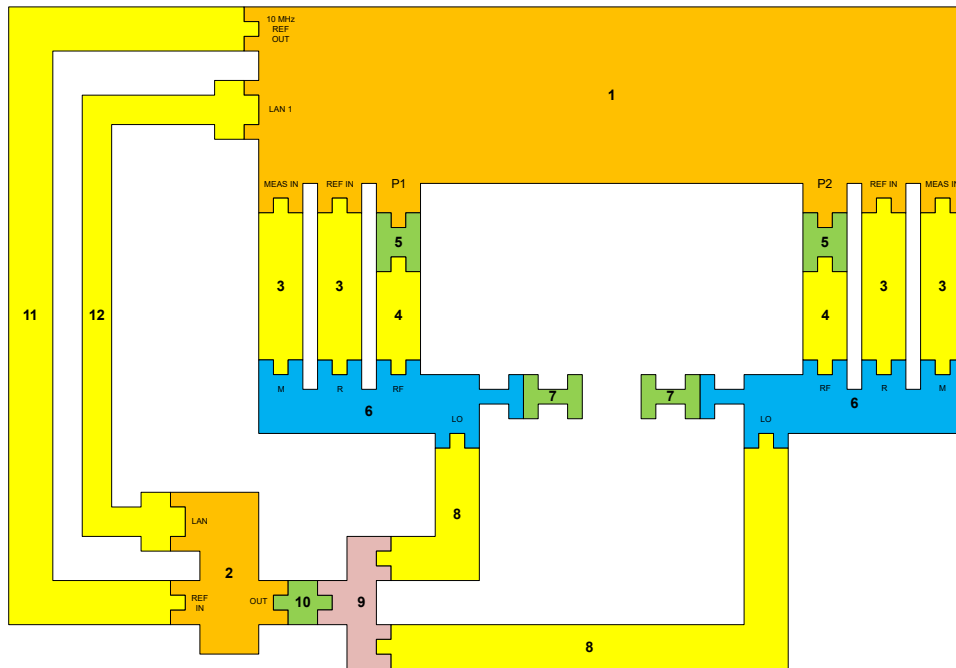
how all components and cables were arranged and whether the waveguide connections were done in horizontal or vertical manner.

If only 1-port measurements are required, it might be advantageous to use a vertical set-up. Thus, gravity effects should not introduce any systematic influence on the waveguide connections. A vertical set-up can be achieved by using a waveguide bend or by vertically positioning the extender head. For the latter, a customized fixture might be required. For both horizontal and vertical arrangements, one should aim to have a mechanically stable set-up: no unnecessary movements or vibrations. Schematic drawings for two different set-ups are given in Figure 7.

Depending on the manufacturer, the internal VNA settings e.g. AGC (automatic gain control) can influence the overall measurement uncertainty. Therefore, one should check these setting beforehand. This is even more important if the VNA firmware is not used for the calibration. If the uncalibrated (raw) data is measured, e.g. for use with custom calibration routines, the operator should check the following:

1. Receiver settings (AGC, ...)
2. Possible pre-calibrations





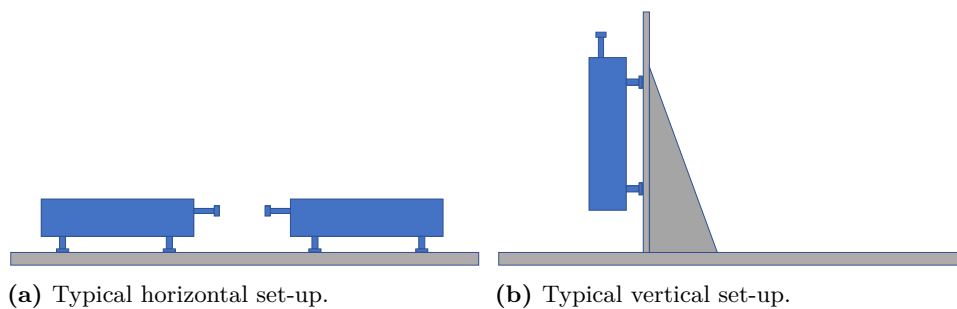
**Fig. 6.** Schematic measurement set-up with 2-port VNA, synthesizer and frequency extenders.

- 1 : 2-port VNA
- 2 : Signal generator
- 3 : Cable 2.4 mm plug →2,92 mm plug
- 4 : Cable 2,92 mm plug →2,92 mm plug
- 5 : Adapter 2.4 mm jack →3.5 mm jack
- 6 : Frequency Extender
- 7 : Adapter R900 →R900
- 8 : Cable 3.5 mm plug →3.5 mm plug
- 9 : Power Splitter 3.5 mm jack
- 10 : Adapter 3.5 mm plug →3.5 mm plug
- 11 : BNC Cable
- 12 : Ethernet Cable

### 3. Correct recording of switch terms

### 3.3 Some practical tips

Much of the information given in [23] (chapter 8: Best measurement practice and practical advice) can also be applied to waveguide measurements above 100 GHz. This section focuses on good measurement practice for typical waveguide applications.



**Fig. 7.** Extender head positions: (a) horizontal, and (b) vertical.

### 3.3.1 Use of a precision waveguide section as a test interface

Over time and with use, the waveguide interfaces of VNA frequency extenders can become damaged or worn, and this impacts directly on measurement repeatability. It is good practice to fit short precision waveguide straight sections to the frequency extender test ports since these can easily be removed for inspection and calibration without invalidating manufacturers' warranties. This procedure is well known from coaxial measurements. The additional coaxial adapter is often called a "connector saver" or "interface saver".

### 3.3.2 Different waveguide apertures

If the same flange is used, it is possible to connect waveguides with different aperture sizes. This may even be intended in some applications, like e.g. for the VDI power meter PM5 [16]. The PM5 is equipped with a WR-10 waveguide, but it is possible to measure power levels at frequencies much higher than 110 GHz (even up to 3 THz).

Above a certain frequency however, more than one waveguide mode can propagate in the larger aperture, and it becomes difficult to predict how much energy of the actual signal is distributed to which mode. This may even change for each new flange connection (different excitation conditions), and the repeatability of such measurements should be checked very carefully. In general, it is recommended to use WG apertures of the same size or to introduce a WG taper. This should minimise coupling into unwanted modes, but does not completely eliminate it.

### 3.3.3 Waveguide to coaxial adapters

For 'normal' coaxial or waveguide devices it should not matter, at which orientation they are connected to the test ports. This is different for coaxial to waveguide adapters. The TEM (transverse electromagnetic) mode of the coaxial line is symmetrical to the inner conductor, the TE (transverse electric) mode of the waveguide is not. If the transmission coefficient of a

waveguide to coaxial adapter is measured, the phase will change by  $180^\circ$ , if the waveguide connection to the test port is rotated by  $180^\circ$ . The reflection coefficient remains unchanged. This effect poses usually no problem, because in data sheets of such adapters often only the magnitude of the insertions loss is given. If, however, a calibration certificate (or similar document) includes all complex S-Parameters of a coaxial to waveguide adapter, the waveguide flange orientation during measurement must also be stated in such a document.

### 3.4 Example Measurements

In this section, some WG measurements are presented and discussed. The focus lies on the repeatability of flange connections and the drift influences of the measurement equipment. The flanges that are used are:

- UG-387, i.e. the type of flange that most measurement devices are equipped with.
- IEEE 1785.2a, precision flange for frequencies up to THz.

The original UG-387 flange design does not have any inner precision alignment holes. But, to achieve better repeatability, some manufacturers added inner alignment holes before IEEE or IEC published the new standards. The dimension and tolerance of these holes and associated dowels are often not the same, between different manufacturers, thus an operator must be very careful about connecting flanges that look similar, at first glance, to avoid damage due to these dimensional differences.

To characterise a flange in terms of repeatability, one can do an analysis of repeated connections of stable devices under test (DUT), e.g. a matched load or a short [23]. But it is also possible to estimate the repeatability based on the tolerance of the alignment mechanisms of the flange.

The maximum misalignment for the UG-387 flange is approximately  $150\ \mu\text{m}$  in both the H- and E-plane, and the maximum angular misalignment is  $1.2^\circ$ . For the IEEE 1785.2a flange, the maximum misalignment is  $25\ \mu\text{m}$  in the H-plane,  $20\ \mu\text{m}$  in the E-plane, and the maximum angular misalignment is  $0.4^\circ$ . With this information and modern simulation tools, the worst case return loss can be calculated [4], [27]. Table 4 shows these worst case return loss

	UG-387	IEEE.2a
WR 10 / WM-2540	$\approx -30\ \text{dB}$	$-60\ \text{dB}$
WR 03 / WM-864	$\approx -12\ \text{dB}$	$-39\ \text{dB}$
WM-570	$\approx -8\ \text{dB}$	$-32\ \text{dB}$

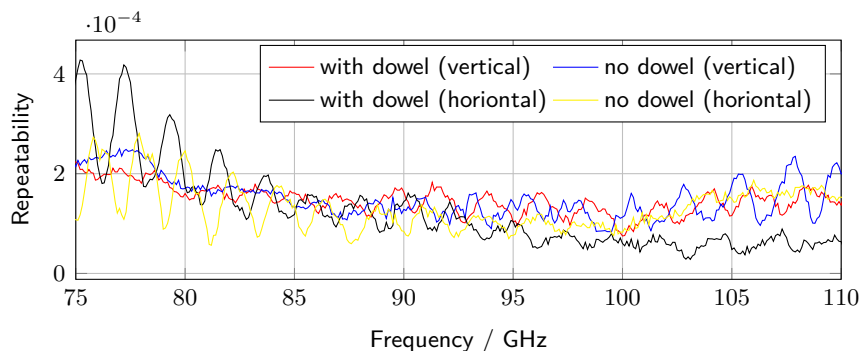
**Table 4.** Theoretical flange performance for selected WG dimensions of UG-387 (not modified, without inner precision holes) and IEEE Std. 1785.2:2016.

values for standardised flange connections. This table shows that the UG-387 flange is not really suitable for use at frequencies above approximately 110 GHz. The repeatability should usually be better than the worst case return loss. In the following, it is shown, that this is not always the case.

### 3.4.1 Measurements for 75 to 110 GHz: WR10 / WM-2540 / R 900 / WG 27

The frequency band 75-110 GHz is the lowest band supported by the IEEE standard, but the UG-387 flange is usually precise enough to get a reasonable good repeatability and reproducible measurement results for these frequencies and is therefore still widely used.

In Figure 8 the repeatability is shown for a matched DUT for a horizontal and a vertical measurement set-up (to reduce gravity offsets) and with and without additional inner alignment dowels used.

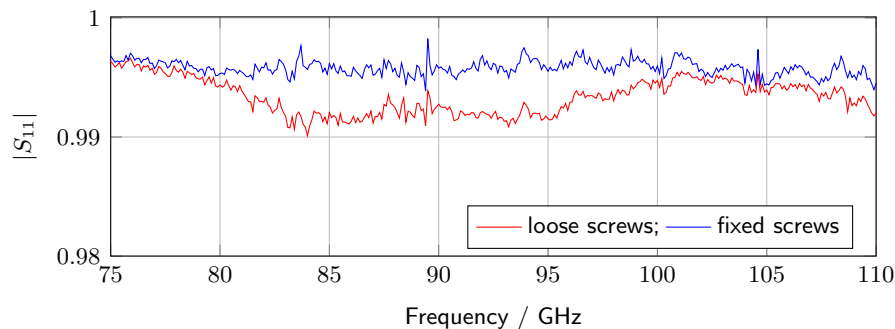


**Fig. 8.** Repeatability evaluation with four measurements for vertical and horizontal position with and without alignment dowels.

The repeatability was calculated as describe in [23]. It is obtained from repeated measurements of a stable DUT and calculating the maximum differences, taking both the real and imaginary components into account. This is a very conservative approach and outlier sensitive, but it acknowledges the fact that the repeatability can strongly vary from one flange pair to another. As can be seen, the different cases yield very similar repeatability results and are always better than 0.0316, ( $\approx -30$  dB, see Table 4).

For a connection with the UG-387 flange four screws must be tightened. Because in some set-ups one or more screws might be difficult to reach (or due to time reasons) some operators do not use all four screws. This is likely to have a significant influence not only on the repeatability, but also on the measured value, as is shown in Figure 9.

One should always use all four screws and also a suitable torque to tighten the screws. The latter can be a difficult task, because the torque is not standardised, and manufacturers specify different values [24], [28]. The



**Fig. 9.** Calibrated return loss measurements of a flush short-circuit.

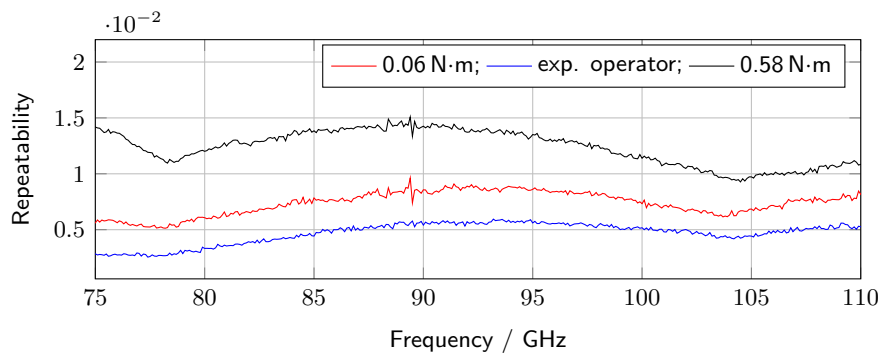
torque needed to produce a precise and reproducible waveguide connection is at least dependent on:

- base material of the flanges (e.g. copper, beryllium copper, brass, aluminium, etc.),
- thickness of the flange (i.e. the flange could be formed using a block)
- quality of the threaded holes and screws (different friction loss),
- surface material (often several metal layers, e.g. nickel, gold, silver, etc.),
- surface flatness,
- surface roughness.

For a high quality pair of flanges (i.e. with flat surface and low surface roughness, etc.) a very small torque is often sufficient to achieve a good repeatability for waveguide connections. But, of equal importance as the torque is the weight of a DUT for horizontal set-ups or the alignment of a second extender head for horizontal set-ups (needed for 2-port measurements). Both might reduce the effective torque on the interface itself very much and give the wrong impression, e.g. that a high torque must always be used.

In Figure 10 the repeatability is shown for two torque values (0.06 N·m and 0.58 N·m) as well as for the torque achieved by an experienced operator. The latter is estimated to be approximately 0.3 N·m (verified with a calibrated torque meter).

Figure 10 shows that the repeatability achieved by the experienced operator can be better than that achieved using the specified torque values. It also shows that more (or less) torque does not automatically mean a better connection. This is one reason why values of torque for making waveguide connections are not currently specified in the standards. For example, during connection, an experienced operator can consider other aspects that might impact the quality of the connection – e.g. the weight of the component being connected when tightening the flange screws. However, it is still usually recommended to use torque drivers to achieve reproducible results.



**Fig. 10.** Repeatability measurements [23] of an offset-short for different torques.

When performing repeatability tests, one should not blindly do the statistical analysis but also investigate the single measurements to identify any possible outliers caused by poor connections. Figure 11 shows the difference of the single reflection coefficient measurements  $\Gamma_n$  to the mean value  $\Gamma_{\text{all,mean}}$  of all repeatability measurements for two experiments with the same DUT (short-circuit). In Figure 11(a), two outliers (measurement 3 and 4) can be identified. These should not be taken into account for the repeatability calculation. If the number of remaining measurements is too few (at least 4 or more should be used), one should repeat the experiment completely. In Figure 11(b), the repeated experiment (performed with more care) without outliers is shown.

All repeatability measurements might also be distorted due to:

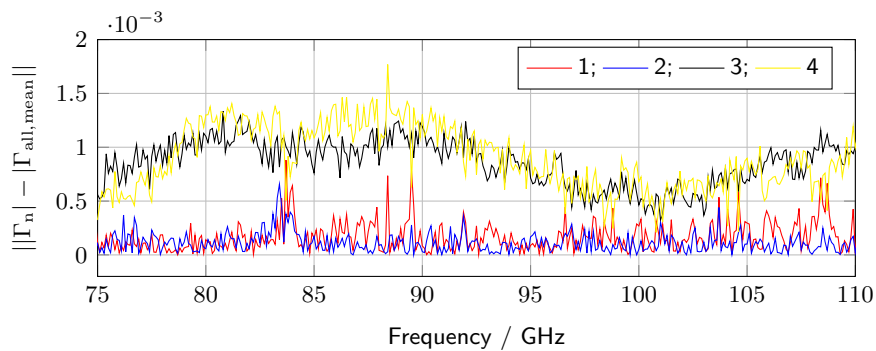
- Noise,
- Drift,
- Cable movements.

Depending on the measurement scenario, 1-port measurements usually don't require cable movement, the latter one can often be avoided completely.

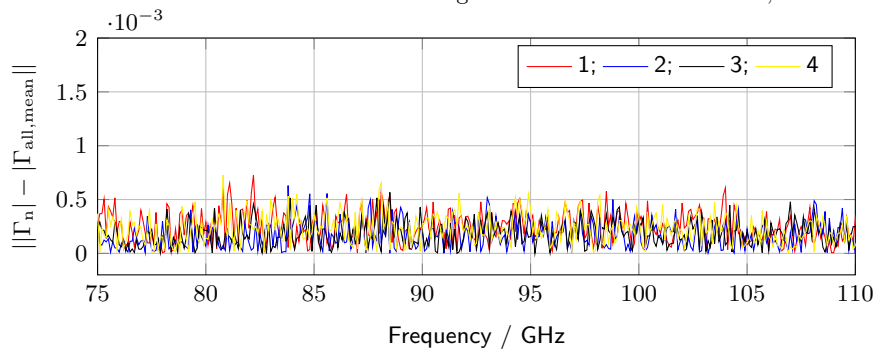
Even if not a complete uncertainty budget is required, the procedure to get this are given in [22], [23], one should still do some simple tests to quantify these effects. For example to get an idea how large the instrument drift is, one can do a series of measurements (e.g. one every 60 sec.) of a stable DUT (without reconnecting). In Figure 12 the drift result of such a measurement is shown for the linear reflection coefficient of a flush short-circuit.

The values are obtained by simply calculating the difference to the first measurement. The drift for 4 measurements (corresponds to 4 minutes) at the beginning and at the end of a experiment is nearly identical and approximately  $1 \cdot 10^{-3}$ . The drift for 15 measurements (corresponds to 15 minutes) is somewhat larger and of the same order of magnitude as the expected repeatability.

In Figure 13 the cable stability is shown after performing the test pro-

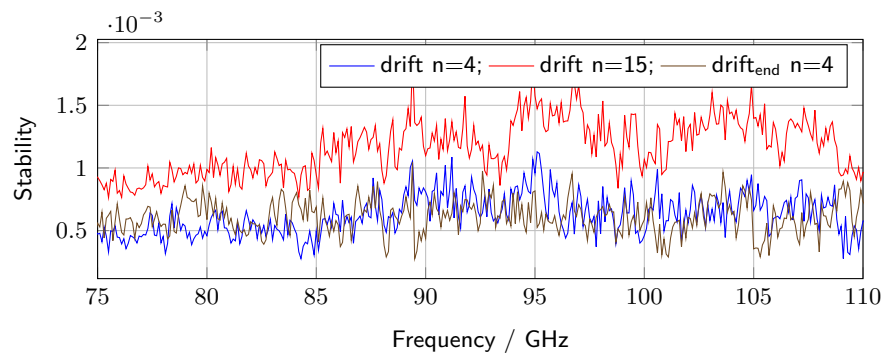


(a) Difference between reflection coefficient magnitudes and their mean value, with outliers.



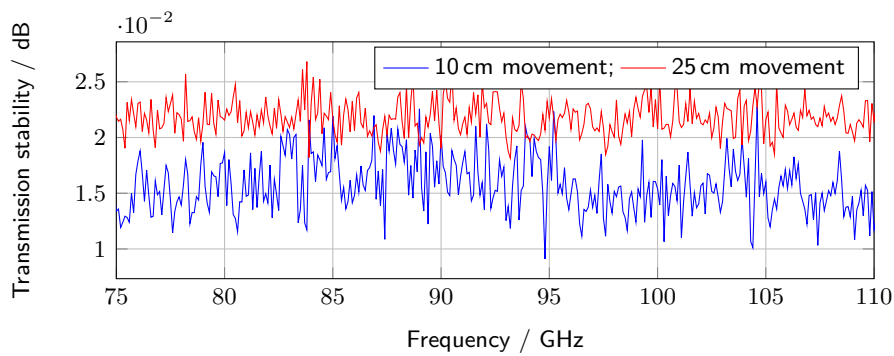
(b) Differences between reflection coefficient magnitudes and their mean value, without outliers.

**Fig. 11.** Reflection measurements of a stable DUT normalised to the mean of  $n=4$  measurements: (a) port 1 and (b) port 2.

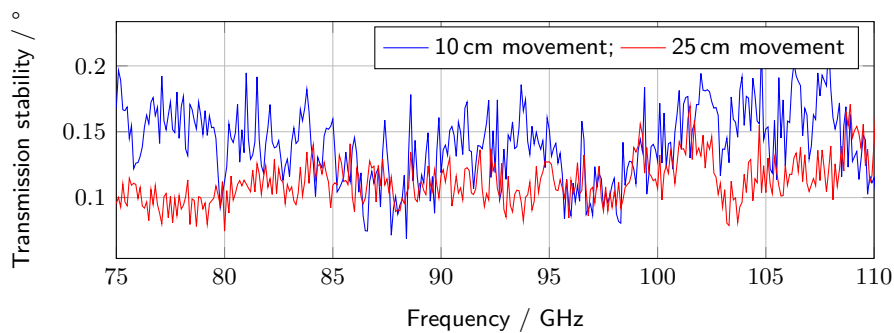


**Fig. 12.** Stability evaluation (drift) with  $n=15$  measurements, one measurement each minute.

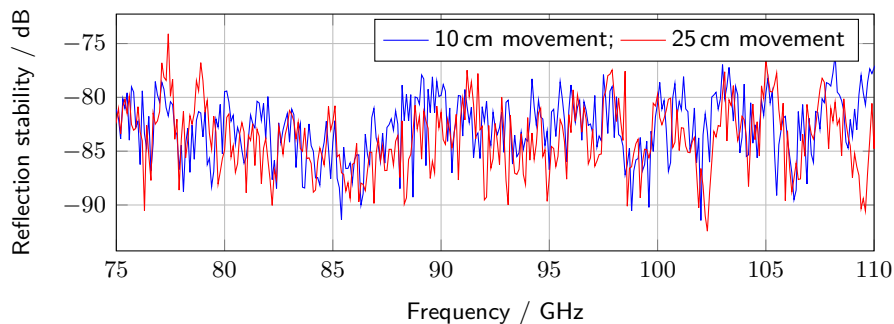
cedure given in [23]. This consists of repeated movements and reflection measurements of a cable (here several cables including frequency extender) terminated with a matched load and a short-circuit and calculating the maximum differences, taking both magnitude and phase into account.



(a) Transmission stability in dB (cg-12)



(b) Transmission stability in deg (cg-12)



(c) Reflection stability in dB (cg-12)

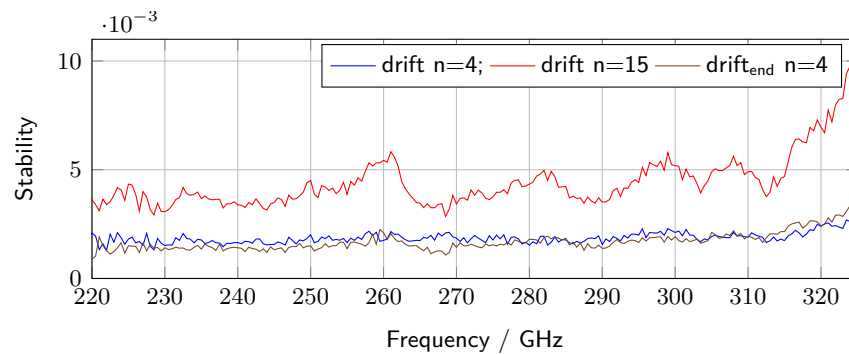
**Fig. 13.** Cable stability [23] for 10 cm and 25 cm cable movements.

In this case, the results are in the order of magnitude one would expect at these frequencies and don't change much for cable movements of 10 cm or 20 cm. This indicates, that all cables connected to the extenders are quite stable. If the results are not as good as expected, one should test all cables separately. Usually this involves coaxial measurements up to only 20 GHz or less and following the same procedure.



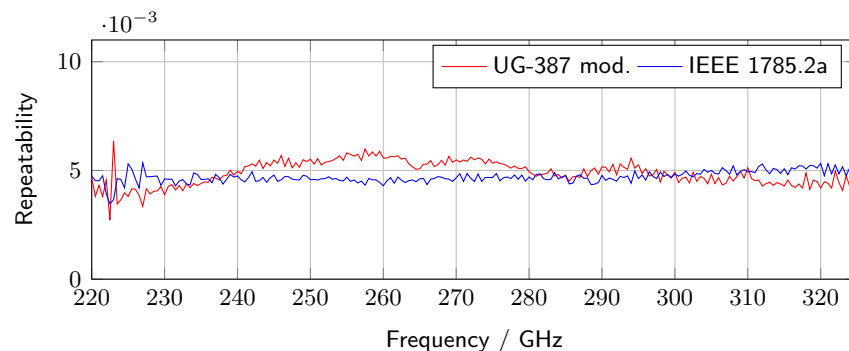
**3.4.2 Measurements for 220 to 330 GHz:  
WR3 / WM-864 / R 2.6k / WG 32**

The waveguide band 220 GHz to 330 GHz is supported by the flanges described in IEEE Std. 1785.2-2016 and the UG-387 flange. Although the UG-387 flange can be used at these frequencies, it is not recommended, unless a modified version incorporating improved alignment features is used. The IEEE Std. 1785.2-2016 flange designs provide better electrical performance at these frequencies.



**Fig. 14.** Stability evaluation (drift) with  $n$  flush short-circuit measurements.

In Figure 14 the stability based on repeated measurements on a fixed timescale (one every 60 sec.) of a stable DUT (without reconnecting) is evaluated. Compared to the measurements up to 110 GHz, see Figure 12, the system drift is larger. In 4 minutes it is approximately  $2 \cdot 10^{-3}$  and for 15 minutes it reaches  $10 \cdot 10^{-3}$  at the highest frequency. The main reason for this is the lower stability of the frequency extenders, thus any repeatability measurements are strongly superimposed by the instrument drift.



**Fig. 15.** Repeatability measurements [23] of a stable DUT for different flanges.

In Figure 15 repeatability measurements are shown for different flange configurations: standard flange of the frequency extender (modified UG-

387 with additional inner dowels) and the flange IEEE Std. 1785.2a. The evaluated repeatability indicates similar results for both configurations. In theory the IEEE 1785.2a flange with the two different precision dowels (angular (◄) and rectangular (■)) should be superior. But the repeatability is superimposed by the instrument stability, as both phenomena are of the same order of magnitude.

## 4 Software

In this section some software tools are listed and reference, that support measurements of waveguides at 100 GHz and above.

### 4.1 Software for Uncertainty Calculation of Waveguide Connections

#### **NIST IEEE P1785 Rectangular-Waveguide Uncertainty Calculator**

The NIST IEEE P1785 Rectangular-Waveguide Uncertainty Calculator software package implements the guidelines given in IEEE Std 1785.3-2016 "IEEE Recommended Practice for Rectangular Metallic Waveguides and Their Interfaces for Frequencies of 110 GHz and Above—Part 3: Recommendations for Performance and Uncertainty Specifications". The software translates measured mechanical uncertainties in flanges and electrical flange repeatability information into uncertainties in S-parameters.

#### **METAS VNATools II**

VNA Tools II is a metrology software for the vector network analyser. The software controls the VNA and evaluates measurement uncertainty in accordance with the GUM (Guide to the Expression of Uncertainty in Measurement). VNA Tools II is publicly available [29]. A spin-off product of VNATools II is the generic uncertainty calculation software METAS UncLib.

#### **NIST Microwave Uncertainty Framework (MUF)**

The NIST Microwave Uncertainty Framework provides a "drag-and-drop" toolkit for managing the calculation of uncertainties in VNA and other measurements. The framework makes it easy to construct models for calibration standards and automates the calculation of uncertainties with both a conventional linear error-propagation analysis and a Monte-Carlo analysis capable of propagating uncertainties through nonlinear models. The framework includes a VNA Uncertainty Calculator for guiding the generation of uncertainties in scattering parameters. The framework also includes a post processor that allows the uncertainties in measured scattering parameters to be propagated to derived measurement quantities. This is general VNA software for evaluating uncertainty in a wide range of measurement types, including waveguides at millimetre-wave and terahertz frequencies.

## References

- [1] “IEEE standard for rectangular metallic waveguides and their interfaces for frequencies of 110 GHz and above—part 1: Frequency bands and waveguide dimensions”, *IEEE Std 1785.1-2012*, pp. 1–22, Mar. 2013.
- [2] IEC 60153-2:2016, *Hollow metallic waveguides - part 2: Relevant specifications for ordinary rectangular waveguides*, 2016.
- [3] MIL-DTL-3922/67E w/Amendment 1, *Flanges, waveguide (contact), (round, 4 hole) (millimeter)*, 2014.
- [4] “IEEE standard for rectangular metallic waveguides and their interfaces for frequencies of 110 GHz and above—part 2: Waveguide interfaces”, *IEEE Std 1785.2-2016*, pp. 1–22, Sep. 2016.
- [5] IEC 60154-2:2016, *Flanges for waveguides - part 2: Relevant specifications for flanges for ordinary rectangular waveguides*, 2016.
- [6] SPINNER GmbH, *Flanges for ordinary rectangular waveguides*, TD-00077, 2018. [Online]. Available: [https://www.spinner-group.com/images/download/technical\\_documents/SPINNER\\_TD00077.pdf](https://www.spinner-group.com/images/download/technical_documents/SPINNER_TD00077.pdf) (visited on 01/09/2019).
- [7] Maury Microwave Corporation, *Coaxial & waveguide adapters*, 2008. [Online]. Available: <https://www.maurymw.com/pdf/datasheets/wgflngs.pdf> (visited on 02/05/2019).
- [8] OML Inc., *Waveguide flange designation*, 2015. [Online]. Available: [https://www.omlinc.com/images/pdf/Library/References/Waveguide\\_Flange\\_Designation.pdf](https://www.omlinc.com/images/pdf/Library/References/Waveguide_Flange_Designation.pdf) (visited on 02/05/2019).
- [9] SPINNER GmbH, *Cross reference for hollow metallic waveguides*, 2018. [Online]. Available: [https://www.spinner-group.com/images/download/technical\\_documents/SPINNER\\_TD00036.pdf](https://www.spinner-group.com/images/download/technical_documents/SPINNER_TD00036.pdf) (visited on 01/09/2019).
- [10] A. R. Kerr, E. Wollack, and N. Horner, “Waveguide flanges for alma instrumentation”, *ALMA Memo*, vol. 278, 1999.
- [11] D. Pozar, *Microwave Engineering*, 4, Ed. Wiley, 2011, ISBN: 9781118213636.
- [12] Oleson Microwave Labs. [Online]. Available: <https://www.omlinc.com/> (visited on 02/12/2019).
- [13] RPG-Radiometer Physics GmbH. [Online]. Available: <https://www.radiometer-physics.de/> (visited on 02/12/2019).
- [14] C. Oleson and A. Denning, “Millimeter wave vector analysis calibration and measurement problems caused by common waveguide irregularities”, in *Proc. 56th ARFTG Conf. Digest*, vol. 38, Nov. 2000, pp. 1–9.
- [15] C. Oleson, A. Denning, and Y. Lau, “325 to 500 GHz vector network analysis system”, in *Proc. 66th ARFTG Microwave Measurement Conf. (ARFTG)*, Dec. 2005, pp. 1–7.
- [16] Virginia Diodes. [Online]. Available: <https://www.vadiodes.com/> (visited on 02/12/2019).
- [17] T. W. Crowe, B. Foley, S. Durant, K. Hui, Y. Duan, and J. L. Hesler, “Vna frequency extenders to 1.1 THz”, in *Proc. 2011 Int. Conf. Infrared, Millimeter and Terahertz Waves*, Oct. 2011, p. 1.
- [18] M. Niman, “Improved accuracies for rectangular waveguide data”, in *Proc. European Microwave Conf*, Sep. 2006, pp. 1374–1376.
- [19] J. S. Ward, “New standards for submillimeter waveguides”, in *Proc. 17th Int. Symp. on Space THz Tech*, 2006.

- [20] J. Hesler, A. Kerr, W. Grammer, and E. Wollack, “Recommendations for waveguide interfaces to 1 thz”, in *18th International Symposium on Space Terahertz Technology*, 2007.
- [21] N. Ridler, “Recommendations for waveguide sizes at submillimeter wavelengths”, in *Proc. 73rd ARFTG Microwave Measurement Conf*, Jun. 2009, pp. 1–7.
- [22] “IEEE recommended practice for rectangular metallic waveguides and their interfaces for frequencies of 110 GHz and above—part 3: Recommendations for performance and uncertainty specifications”, *IEEE Std 1785.3-2016*, pp. 1–19, Oct. 2016.
- [23] *Guidelines on the Evaluation of Vector Network Analysers (VNA)*, Calibration Guide No. 12, Version 3.0, EURAMET, 2018. [Online]. Available: <https://www.euramet.org/publications-media-centre/calibration-guidelines/>.
- [24] M. Horibe, “Connection torque consideration for waveguide flange at millimeter-wave and terahertz frequencies”, in *Proc. 87th ARFTG Microwave Measurement Conf. (ARFTG)*, May 2016, pp. 1–4.
- [25] OML Inc., *Basic tips and steps for waveguide care and usage*, Application Note, 2016. [Online]. Available: [https://www.omlinc.com/images/pdf/Library/Application\\_Notes/Waveguide\\_Care\\_App\\_Note.pdf](https://www.omlinc.com/images/pdf/Library/Application_Notes/Waveguide_Care_App_Note.pdf) (visited on 02/05/2019).
- [26] M. Zeier, J. Hoffmann, J. Ruefenacht, D. Stalder, and M. Wollensack, “Mechanical aspects in mm-wave measurements”, in *2016 Conference on Precision Electromagnetic Measurements (CPEM 2016)*, Jul. 2016.
- [27] A. R. Kerr, “Mismatch caused by waveguide tolerances, corner radii, and flange misalignment”, *Electronics Div. Tech. Note*, vol. 215, 2010.
- [28] T. Schrader, K. Kuhlmann, R. Dickhoff, J. Dittmer, and M. Hiebel, “Verification of scattering parameter measurements in waveguides up to 325 GHz including highly-reflective devices”, *Advances in Radio Science*, vol. 9, pp. 9–17, Jul. 2011.
- [29] M. Wollensack and J. Hoffmann, *METAS VNA Tools II - Math Reference V2.1*, [www.metas.ch](http://www.metas.ch), 2018.